

PIEZO
FEEDER / *P111 (P111-F)*
CONTOROLLERS / *P211 (P211-F)*
/ *P311 (P311-F)*

Digital Controller for a Piezo Feeder

Instruction Manual

Request

Always store this operation manual with great care near the machine. Prior to use, be sure to read this operation manual and understand it thoroughly so that the work may be done safely by correct operation.



8-122, Kiba-cho, Minato-ku, Nagoya, Aichi pref. 455-0021, Japan

TEL +81 52-691-1147

FAX +81 52-692-1915

1. Introduction

Thank you very much for purchasing our digital controller for a piezo feeder.

The piezo feeder is a high-efficiency and energy-saving type of a parts feeder employing piezo-electric elements as its driving force.

In combined use with a special digital controller, it can be used effectively with simple operation without difficult adjustments.

Prior to starting connections with the piezo feeder and adjustments, read this operation manual thoroughly and understand superb functions of the piezoelectric parts feeder for proper operation.

2. Checking at the time of purchase

Handle the package with care to avoid impacts and vibrations.

After unpacking, check to see that

(1) no part is damaged in transit.

(2) the rating, capacity and model number on the face plate agrees with your order.

After checking these two points, should any problem be found, please notify it to a shop you purchased.

Safety Precautions

<<DANGER>>

DISASSEMBLY Do not disassemble, remodel and try to repair your machine by yourself. This could cause an electric shock, fire and injury. Have your machine repaired through the shop you purchased from.

PROHIBITION

Do not remove the terminal block cover while the machine is energized. This could cause an electric shock.

Do not put or insert an object into the machine.

Do not splay water or other liquid. This could cause an electric shock and fire.

CARE

To avoid the risk of an electric shock, fit the terminal block cover first and then turn the power on.

In case that any abnormal condition such as smoking, abnormal odor and the noise are encountered, shut off the input power immediately. The continued use of the machine under such conditions could cause a fire. Contact our sales outlet.

In case the machine is not used for a long time, shut off the input power. If the machine is kept energized for a long time, it could cause a fire.

<<CAUTION>>

PROHIBITION Do not turn the power on and off frequently. This could result in a machine failure.

3. Standard specifications

Model	P111 (-F)	P211 (-F)	P311 (-F)
Functions	Voltage and frequency can be digitally changed. Power supply for piezoelectric parts feeder		
Input	Voltage <AC V>	100 - 220V ±10%	
	Frequency <Hz>	50/60	
	No. of phases	Single phase	
Output	Rated current (mA)	25	110
	Voltage <VAC>	0 - 240 ±10%	
	Voltage stability	± 5% or less (with reference to input fluctuation)	
	Frequency <Hz>	± 5% or less (with reference to output fluctuation)	
External control method	60 - 400		
External control method	Control by no-voltage contact using built-in DC power source or no-contact control by external supply voltage (12 - 24 VDC)		
Operating temperature (°C)	0 - 40 (To be free from freezing)		
Operating humidity (%Rh)	10 - 90 (To be free from condensation)		
Receiving power capacity (VA)	30 (45)	65 (80)	85 (100)
Weight (kg)	1.2	2.7	2.7

4. Names and functions of operating switches

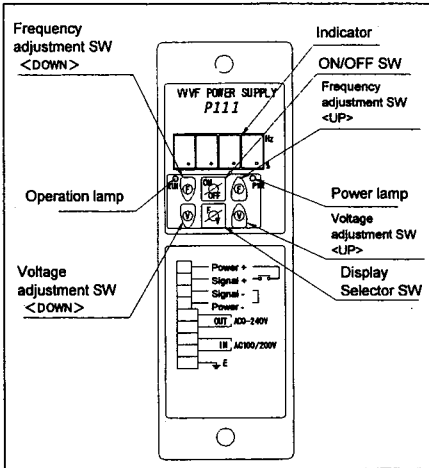

1) Frequency adjustment switch <UP>
 Frequency adjustment switch <DOWN>
 Use this switch for adjusting frequency.
 Frequency can be adjusted even when the indicator is not displaying frequency.

2) Voltage adjustment switch <UP>
 Voltage adjustment switch <DOWN>
 Use this switch for adjusting the output voltage.
 Voltage can be adjusted even when the indicator is not displaying voltage.

3) Indicator
 The indicator displays the output frequency (Hz) and output voltage %. It also displays an error code when an error is detected.

4) ON/OFF switch
 Operation can be started or stopped regardless of external control signal.

Description of <Indicator>

OVoltage (%)

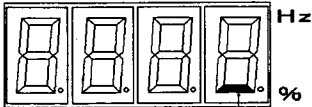

A bar (-) is highlighted beside the letter %.

ODisplay when frequency is adjustable (unlocked)

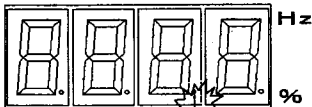

The decimal point blinks.

ODisplay when frequency is fixed (locked)

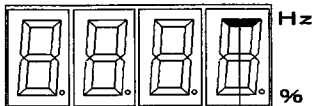

A bar (-) is highlighted beside the letter Hz.

5) Operation lamp
 The lamp lights up during operation. The operation lamp blinks only when OFF is selected by the ON/OFF switch on the panel in case that the external control is ON.

6) Power Lamp
 The lamp lights up when the power is turned on. It blinks when an error occurs.

7) Display selector switch

- Use for switching the indicator.
 Every time the switch is pressed, the current status is highlighted.

Frequency → Voltage (%) → Frequency

- Frequency lock function

Frequency is locked by pressing this switch long (for over 2 seconds). Frequency is not changed even if other switch is operated when frequency is locked. By pressing the display selector switch long again, frequency is unlocked.

5. Connection

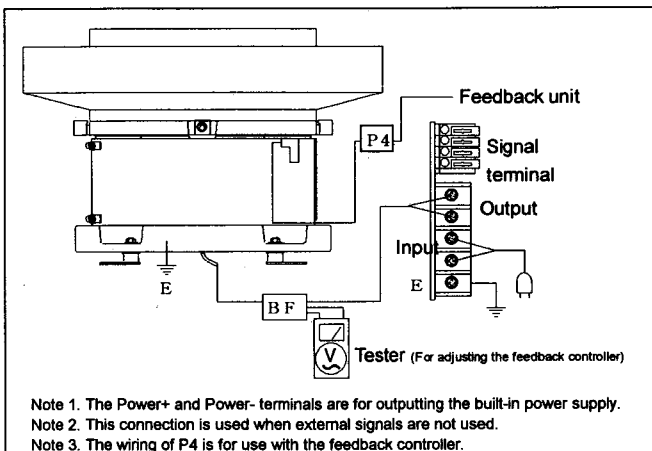

ATTENTION

1. Never connect the power supply (100V or 200V) with a signal terminal to avoid the burnout of the controller.
2. Be sure to connect to ground for safe operation.
3. Be sure to ground the controller and vibrator to avoid malfunction when a photoelectric sensor is used.

6. Installation of feedback unit

(Only when the feedback unit is purchased separately)

Caution in installing the feedback unit

Be sure to shut the power off before installing
 <May cause an electric shock and system damage>

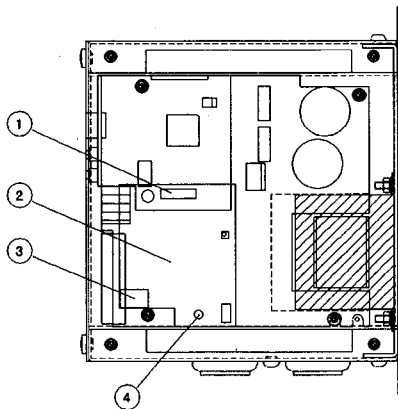

Installation of feedback unit

1) Insert the feedback unit board ② into the white connector ① on the P-series main board.

2) A connector for sensor input <2P> ③ is located under the unit board. Connect Sanki's vibration sensor <KS-3> with this connector.

3) Align the mounting hole under the unit board with the prop ④ extending from the main board and secure them with a screw.

Note. Replace the side cover of P111 with the side cover for feedback controller.

This will complete the installation of the feedback unit.

For the method of setting, see "9. Adjustment".

7. Installation of vibration sensor

Install the vibration sensor as shown below.

Secure a lead wire on the top plate with a saddle to avoid adverse effects caused by vibration.

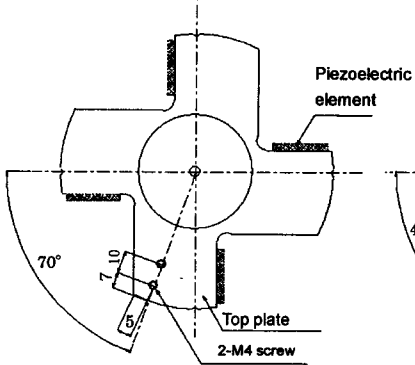

Smaller type PEF-90A to 120A

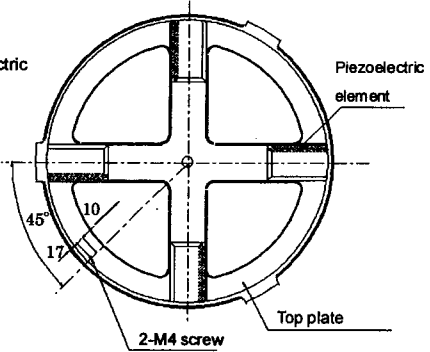

Larger type PEF-150A to 460B

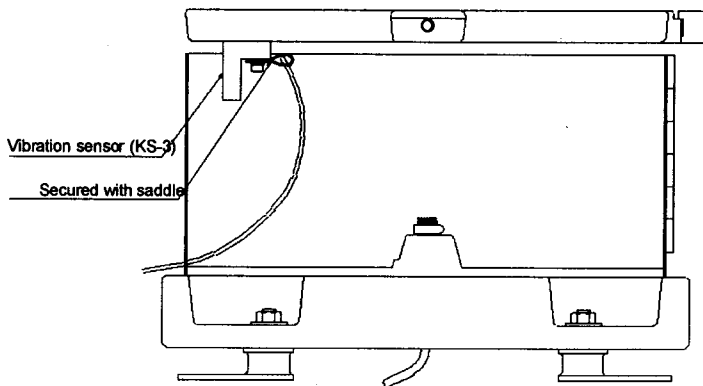

8. Wiring on terminal block

In case of P111

Remove the front panel and perform the wiring.
The wiring works can be made easier by removing the panel on the right side.
Do not remove screws constructing the box.

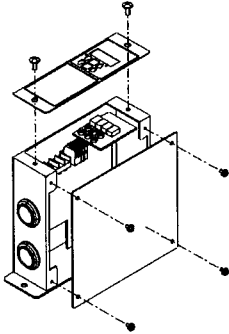

In case of P211/311

Remove two front panels and perform the wiring.
Do not remove screws constructing the box.

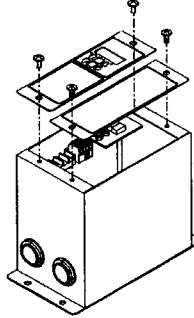

Wire connection of terminal block for external control

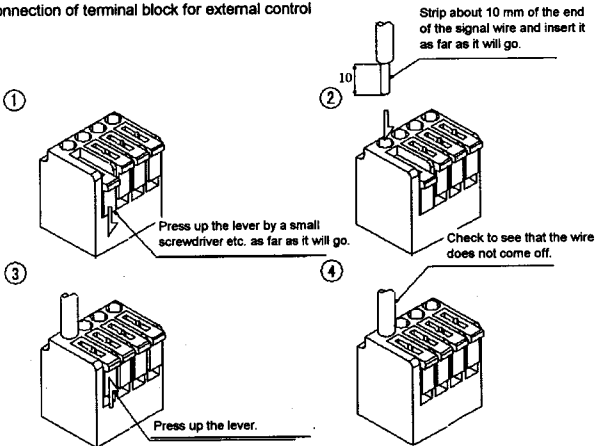

* Model ML-1900-H-4 of SATO PARTS CO., LTD. is used as a terminal block for electric control. Recommended wires are listed below.

Suitable wire rating	Single wire: $\phi 1.0$ mm (AWG18) Stranded wire: 0.75 mm ² (AWG20) Diameter of strand: $\phi 0.18$ or more
Range of applicable wire	Single wire: $\phi 0.4$ mm (AWG26) - $\phi 1.2$ (AWG16) Stranded wire: 0.3 mm ² (AWG22) - 0.75 mm ² (AWG20) Diameter of strand: $\phi 0.18$ or more
Button lock mechanism	Provided

Description on external control signal

This controller is not provided with a power switch. Consequently, if the main power supply is turned on with the external control signal ON, the controller starts output. So pay attention in connection.

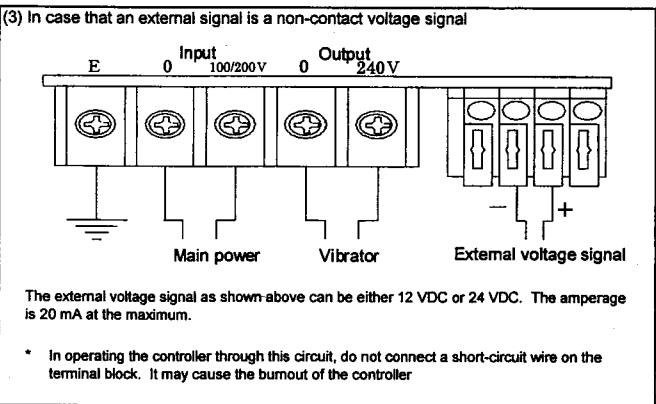
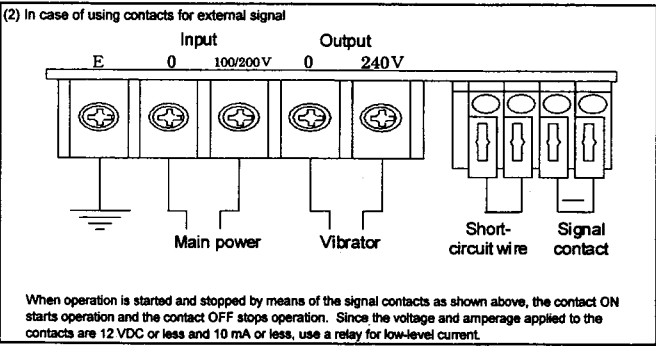
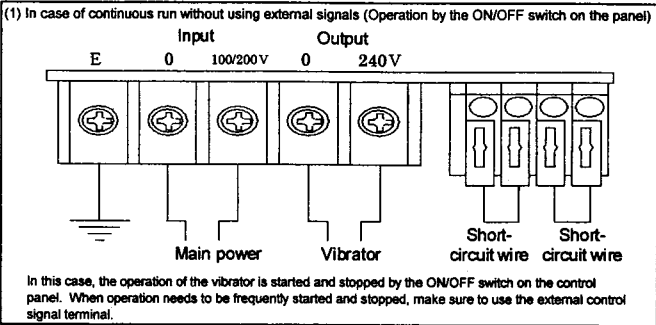

9. Adjustment

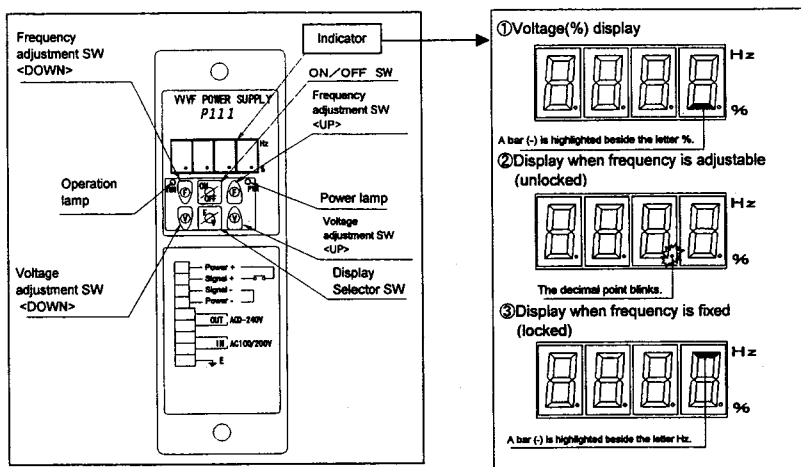

Check to see again that the connection is made correctly. Particular attention should be given to a correct polarity when external signals are used.

- 1) When the power is turned on, the indicator displays <voltage %> (default setting: 0.0%) (As shown in the upper right drawing ①).
- 2) If the ON/OFF switch is pressed in this status or the external control signal is set at RUN, the controller starts output.
- 3) Set an appropriate value by the voltage adjustment switch <UP> (Recommended value: 30 to 50%)
- 4) Press the <F/V> display selector switch to change over to the frequency adjustment display (As shown on the upper right drawing ②). By using the <UP> or <DOWN> switch of the frequency adjustment switch, set the frequency at which works run best.
If vibrators become too large due to coming closer to the resonance point, lower the output voltage.

In case of a feedback controller, make adjustments of frequency monitoring the output voltage by an AC tester. The point where the voltage comes lowest is the resonance point.

- 5) Reduce the output voltage to such a vibration level as will move works slightly, and then make adjustment by the frequency adjustment switch so that works moves best.
- 6) This completes the setting procedure. Switch the display to the voltage % and set the output voltage to a desired speed.
- 7) Lock the setting so as to avoid changing the frequency setting by error. Keep pressing the <F/V> display selector switch long (for longer than 2 seconds) to change the display to the frequency lock (Upper right drawing ③).

- * It is recommended to record the final output frequency and output voltage % for the maintenance in future.

- * The range of the voltage % display is 0.0 to 99.9 and the range of the frequency display is 60.0 to 400.0. (When frequency is locked, fractions below the decimal point are not displayed.)

- * This controller does not display voltage itself. The display indicate the percent with respect to the maximum output value as 100%.

10. Error indication and resetting

In the event of error occurrence, the indicator displays an error code and the power lamp keeps blinking. If this occurs, the controller stops output.

Error Code Table

Description of error	Error Code
Overcurrent error detected	E-01
EEPROM error	E-04

Procedure for Resetting

* How to cancel the error display <See the error code>

- ① Cancel the error by turning the power off
(The setting of frequency and output are maintained as they were when the error was detected.)
- ② Cancel the error by pressing long both the ON/OFF switch and the <F/V> display selector switch simultaneously.
(The setting of frequency and output are maintained as they were when the error was detected.)
- ③ Cancel the error by pressing long both the DOWN switch and the UP switch of the voltage adjustment switch <V> simultaneously.
(The output setting is reset to "0". The setting of frequency is maintained as it was when the error was detected.)

11. Troubleshooting

Problem	Cause	Solution
The vibrator does not vibrate	The voltage (%) setting is 0.0 Frequency (Hz) is not properly adjusted. The output connector is not connected with the vibrator. The operation lamp is not on.	Increase the voltage (%). Adjust the resonance frequency. Connect the connector to the vibrator. Enable external control or press the ON/OFF switch on the panel.
Occurrence of alarm <E-01>	An overcurrent error occurred Fault with the oscillating body? The wire sheath of the controller main body is broken, thereby being earthed.	Lower the voltage setting (%). Contact the stores that you purchased from. Replace the wire.
<E-04>	Computer data error	Contact the stores that purchased from.
The vibrator output is decreased	The voltage indication (%) and frequency indication deviated from the initial setting.	Restore the initial setting. Refer to the memo at the end of this manual.
The power is not turned on	Is the input/output wiring correct?	Correct the wiring.
Frequency cannot be adjusted	Is the frequency adjustment function unlocked?	Follow the procedure for unlocking frequency.

12. CAUTION

- 1) Do not conduct megger tests on terminals other than input terminals.
- 2) Be sure to connect the earth terminal to ground.
- 3) If the vibrator is not connected to ground, the frequency of the vibrator becomes unstable, thus making it difficult to adjust the frequency of the controller. So be sure to connect both vibrator and controller to ground

13. List of accessories

Cable	Product name	Length	Terminal		Remarks
Signal short-circuit cord					Common
Power input cable	VCTFK0.75x2	1500	Pin terminal PC2005M	Nichifu Male pin	Used only with feedback controller
Vibrator output cable	VCTFK0.75x2	1500	Molex female terminal 1189ATL	3P receptacle	
Acceleration sensor input cable	LOW NOISE WIRENO.233 (kuramo)	1500	Molex female terminal 1189ATL	2P receptacle	
As options Control input cable	VCTF0.3x4	1500	No particular specification		

Maintenance and inspection

Carry out preventative maintenance to assure normal operation over an extended time period. Inspect periodically inspection every 3 to 6 month depending on the operating condition.

Cut the power supply off before starting maintenance as listed below, wait 10 minutes or longer and then start it.

1. Check for loosened screws and tighten up screws
2. Check for damages at calked portions caused by heating or other reasons
3. Check for damages to electric wires and cables
4. Remove dust and dirt
5. Do not conduct a withstand pressure test.

Parts replacement

This machine comprises a number of electronic components including semiconductors. The following part needs to be maintained periodically as preventive maintenance since it is subjected to aging with time due to its construction or physical properties, resulting in degraded performance and failures. The period specified below for part replacement does not represent the life of the part but is determined by the period of use in which its failure rate becomes higher under normal operating condition.

Capacitor: 5 years

(Excerpt from "Recommendation of periodic inspection of general-purpose inverter" by The Japan Electrical Manufacturers' Association.)

Thank you very much for purchasing our New Feed Back Controller.

Described below are instructions on how to set up the feed back unit.

Has the board of your feed back unit already been screwed on the main board of the controller?

If already screwed, skip the following procedure 1) - 5).

If not screwed yet, follow the steps below.

- 1) Align the white plastic supporter extending from the controller main board into the mounting hole of the feed back unit.
- 2) A connector for connection with the controller main board is located on the backside of the feed back unit.
- 3) Connect this connector with the controller main board, adjust the screw position of the supporter and secure them.
- 4) On the left side of the supporter there is a connector for connection with Sanki's acceleration sensor.
- 5) Insert the connector of the associated acceleration sensor <KS-3> into this connector.

This will complete the setup procedure of the feedback unit.

Then check the setting of the feed back unit.

Viewed from above after the installation of the feed back unit, JP1, JP2, and JP3 are arranged as shown below.

Notes for the use of feed back unit

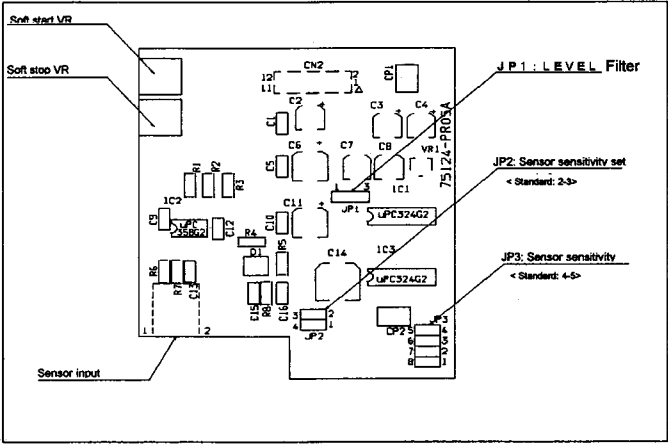

There are two volumes, sensor input and one connector provided on the underside of this plane.

In the standard installation, JP1 <1-2>, JP2 <2-3>, and JP <4-5> are short-circuited.

This completes the standard installation procedure.

The Soft Start and Soft Stop volumes are simple analog volumes that can be adjusted depending on intended use. Turn the volume clockwise to increase the value. If the volume is turned anticlockwise, the value decreases.

By this setting, the vibrator can be started or shut down slowly in a set time, thereby allowing fine adjustment in the operation of the vibrator.

Viewed from the front of controller

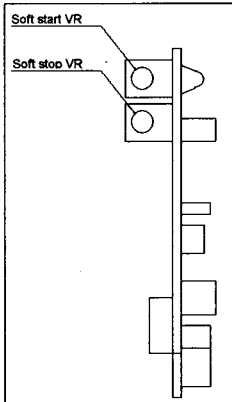

Notes for the setting

- 1) The standard setting of Sanki is JP2 <2-3> and JP3 <4-5>.
- 2) Depending on different features of the vibrator, the setting for JP2 and JP3 may be changed. When changing the setting, observe the notes as below.
- 3) The Soft Start and Stop volumes are not provided with on-off delay features.

CAUTION) Before installing the feed back unit or changing the setting, be sure to shut off the main power.

Note) JP2 can be set at two stages.

The amplification factor changes as follows: PIN 2 - 3 > PIN 1 - 4.

Note) JP3 can be set at four stages.

The amplification factor changes as follows: PIN 4 - 5 > PIN 3 - 6 > PIN 2 - 7 > PIN 1 - 8

Note) In case that a trouble occurs in controlling a large-size vibrator due to too much feed back, the adjustment of the setting of JP2 and JP3 makes it easier to control the vibrator.